



AUTOMATIC SPRINKLERS GL SERIES RECESSED PENDENT TO MEET IBC-ASCE/SEI 7 CODES FOR SEISMIC AREAS C, D & E

DESCRIPTION AND OPERATION

The GL Series Sprinkler is a low profile yet durable design which utilizes a frangible glass ampule as the thermosensitive element. While the Sprinkler provides an aesthetically pleasing appearance, it can be installed wherever standard spray sprinklers are specified. This sprinkler series is available in various styles, orifices, temperature ratings and finishes to meet varying design requirements.

The heart of Globe's GL Series sprinkler proven actuating assembly is a hermetically sealed frangible glass ampule that contains a precisely measured amount of fluid. When heat is absorbed, the liquid within the bulb expands increasing the internal pressure. At the prescribed temperature, the internal pressure within the ampule exceeds the strength of the glass, causing the glass to shatter. This results in water discharge which is distributed in an approved pattern depending upon the deflector style used.

The use of the 4 1/2" diameter recessed escutcheon allows for 1" of clearance around the sprinkler body, and meets the IBC-ASCE/SEI 7 requirements for use in seismic design categories C, D & E.

The sprinkler and escutcheon are not factory assembled. Assembly is done at the time of installation.

TECHNICAL DATA

- See reverse side for Approvals and Specifications.
- Temperature Ratings - 135°F (57°C), 155°F (68°C), 175°F (79°C), 200°F (93°C), 286°F (141°C)
- Water Working Pressure Rating - 175 psi (12 Bars)
- Factory tested hydrostatically to 500 psi (34 Bars)
- Maximum low temperature glass bulb rating is -67°F (-55°C)
- Frame - bronze • Deflector - brass • Screw - brass
- Bulb seat - copper • Spring - nickel alloy • Seal - teflon
- Bulb - glass with glycerin solution, 5mm size
- Escutcheon Assembly - steel



**RECESSED PENDENT
WITH OPTIONAL 4 1/2" SEISMIC
RECESSED ESCUTCHEON**

• **SPRINKLER TEMPERATURE RATING/CLASSIFICATION and COLOR CODING**

CLASSIFICATION	AVAILABLE SPRINKLER TEMPERATURES		BULB COLOR	N.F.P.A. MAXIMUM CEILING TEMPERATURE	
ORDINARY	135°F/155°F	57°C/68°C	ORANGE/RED	100°F	38°C
INTERMEDIATE	175°F/200°F	79°C/93°C	YELLOW/GREEN	150°F	66°C
HIGH	286°F	141°C	BLUE	225°F	107°C

AUTOMATIC SPRINKLERS GL SERIES RECESSED PENDENT TO MEET IBC-ASCE/SEI 7 CODES FOR SEISMIC AREAS C,D & E

SPECIFICATIONS

NOMINAL "K" FACTOR		THREAD SIZE	LENGTH	FINISHES
2.8	(39 metric)	1/2" NPT	2 1/4" (5.7 cm)	Factory Bronze
4.2	(59 metric)	1/2" NPT	2 1/4" (5.7 cm)	Satin Chrome ²
5.6	(80 metric)	1/2" NPT	2 1/4" (5.7 cm)	Bright Chrome
7.8	(111 metric)	1/2" NPT	2 1/4" (5.7 cm)	White Polyester ³
8.1	(116 metric)	3/4" NPT	2 7/16" (6.2 cm)	Black Polyester ³
				Lead Coated ²

NOTE: METRIC CONVERSIONS ARE APPROXIMATE.

²FINISHES AVAILABLE ON SPECIAL ORDER.

³AVAILABLE AS cULus LISTED CORROSION RESISTANT WHEN SPECIFIED ON ORDER.

APPROVALS

STYLE	SIN MODEL	K FACTOR	135°F 57°C	155°F 68°C	175°F 79°C	200°F 93°C	**286°F 141°C	† cULus	FM	LPC	CE	NYC - DOB MEA 101-92-E
PENDENT RECESSED	GL2851	2.8	X	X	X	X	X	X	---	---	---	X
	GL4251	4.2	X	X	X	X	X	X	---	---	---	X
	GL5651	5.6	X	X	X	X	X	X	X	X	X	X
	GL8151*	7.8*	X	X	X	X	X	X	X	---	---	X
	GL8156	8.1	X	X	X	X	X	X	X §	X	X	X

† 5.6K ORIFICE, 7.8K ORIFICE AND 8.1K ORIFICE LISTED FOR ALL HAZARDS.

* 7.8K X 1/2" NPT.

** 286°F cULus LISTED ONLY.

§ BRASS FINISH ONLY

CROSS SECTIONS

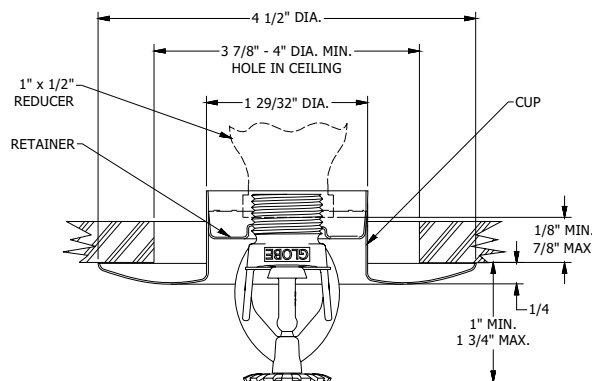

PENDENT WITH OPTIONAL IBC
SEISMIC RECESSED ESCUTCHEON

ORDERING INFORMATION

SPECIFY

- Quantity • Model Number • Style
- Orifice • Thread Sizes • Temperature
- Finishes desired
- Quantity - Recessed Wrenches - P/N 325391, Rev. F (1/2"); P/N 325401, Rev. D (L.O.)
- Quantity - Protective Caps - P/N 327109-CAP (Friction Fit Recessed)

GLOBE® PRODUCT WARRANTY

Globe agrees to repair or replace any of its own manufactured products found to be defective in material or workmanship for a period of one year from date of shipment.

For specific details of our warranty, please refer to Price List Terms and Conditions of Sale (Our Price List).



4077 AIRPARK DRIVE, STANDISH, MICHIGAN 48658

989-846-4583

1-800-248-0278

FAX 989-846-9231

www.globesprinkler.com